

USE OF SIMPLIFIED MATHEMATICAL FORMULATIONS IN MULTI PHASE THERMAL PUMP (MPTP) FOR THEORETICAL PREDICTION OF WORKING CONDITIONS

Francis A. Chami fachami@uccmail.co.tz

Department of Energy Engineering, College of Engineering and Technology
University of Dar es Salaam, P.O. Box 35131, Dar es Salaam, Tanzania

ABSTRACT

In this work mathematical expressions have been formed and solved to get predictions of working parameters of multi phase thermal pump (MPTP). MPTP is a simple pump which uses steam to pump water. The results have been compared with data found experimentally. Experimental and theoretical values for a range of pressures versus velocity differed by approximately 8.7% up to 12%. Through dimensional analysis dimensionless parameters were found Re , Eu , Fr and h/d_{pmp} . These helped to further elucidate the pump's pumping phenomenon. It was experimentally shown that the Reynolds number found theoretically gave limit of flow operating regime of the pump that it is in the transition regime. Above this the pump failed to operate. The Euler dimensionless number gave the dependency of interface velocity on pressure relation, when pressure was raised the velocity increased. The relation between the two parameters was found to be approximately quadratic. The Fourier dimensionless number gave the influence of heat transfer properties of the material of the pump to the operating characteristics. It was experimentally found that the influence of the overall heat transfer coefficient and heat transfer were the main driving forces behind the operation of the pump. Average interface velocities in the pump were found using pipe flow energy and mass conservation equations. Conditions for operation (pumping and suction) of the pump have been established based on the formed mathematical formulations.

Keywords: Steam water pump; pump characteristics; dimensionless parameters; steam

INTRODUCTION

Investigations of simple steam water pump (also known as multi phase thermal pump), with no moving parts and using steam to pump water have been reported in literature [Rao and Rao 1976, Picken 1987, 1990, Picken, et al 1997, Mushi and Chami 2000, Walker and Davidson 1990]. Basically the pump is metal tube which on one end has

separate water and steam inlets and a water outlet on the other end. Non-return valves are employed on all inlets and outlets (Fig.1) The investigations have been mainly based on practical operation of the pump. Only a few related cases of solar pumps do appear in literature, with both experimental and theoretical investigation [Walker and Davidson, 1990].

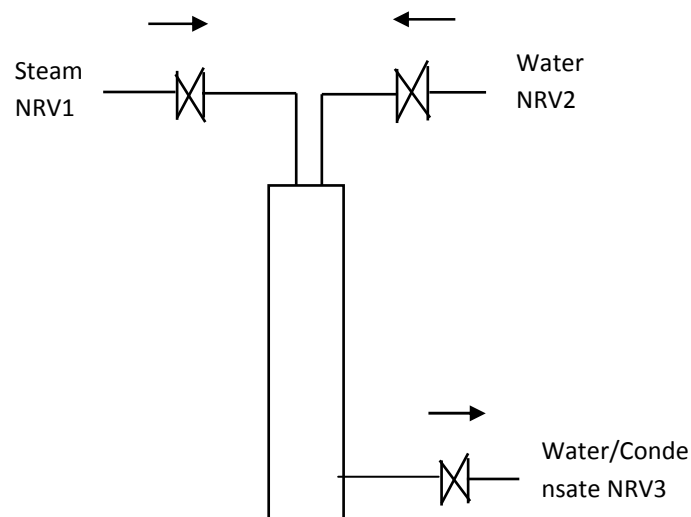

Fig 1: Multi Phase Thermal Pump

The investigations and the results indicate that the discharge head of the pump increases linearly with steam pressure. Its volumetric discharge rate was

influenced significantly by the temperature of the inlet water. For a given inlet temperature, the volumetric discharge rate increases with steam

pressure to a maximum value and decreases thereafter [Mushi and Chami, 2000].

Experimental investigations have been done on pumps of different diameters to obtain data, which could be used to assess performance characteristics and provide necessary information for validating the mathematical formulations.

Given the on going discussions it appeared that there is a need to conduct simplified theoretical work for predicting working conditions already done experimentally.

OBJECTIVES

The objectives of doing this work were to study and formulate simplified mathematical expressions for the operation of pump using one dimensional fluid flow characteristics; to study pumping and suction phenomena of the pump and form equations that will explain these processes including the reversal process. The solution of the equations should give same or near the same results as those found experimentally.

Further objectives were to study influence of the heat transfer from the steam to the pump body and its influence to the pumping processes; to compare the experimental and theoretically obtained results and to use theoretically obtained results to predict working conditions for other designs.

OBSERVATIONS AND FORMULATION

$$\dot{i}_{st} \rho A_p \frac{dh}{d\tau} - \dot{Q}_{wall} - p_{st} A \left(\frac{dh}{d\tau}\right)_{st} - \Delta p_{loss} A \left(\frac{dh}{d\tau}\right)_w - \rho g h_2 A \left(\frac{dh}{d\tau}\right)_w - \rho \left(\frac{dh}{d\tau}\right)_w^2 k / 2 = 0 \quad (2)$$

It was observed that the discharge head of the pump, h_w , is a function of the steam pressure p_{st} , steam - water interface velocity v_{if} , temperature of water T_w , dynamic viscosity of water μ_w , and heat transfer coefficient of the pump body from the steam side α , water density ρ_w and diameter of the pump d_p , that is:

$$h_w = f(\Delta p_{st}, v_{if}, T_w, \mu, \alpha, \rho_w, d_p) \quad (1)$$

From the above explanations, dimensional analysis was used to get dimensionless numbers for the pump. These were found as: Eu, Re, Fo and the fourth non dimensional parameter was the ratio of the head to the pump diameter: h/d . It was experimentally shown that the Reynolds number found gave limit of flow operating regime of the pump. It was in the laminar and transition regime. The Euler dimensionless number gave the dependency of interface velocity on pressure relation. The Fourier dimensionless number gave the influence of heat transfer properties of the material of the pump to the operating characteristics. These were analysed and used to compare the results and explain the phenomenon. Energy involved in the operation of the pump was observed to come from steam. The steam on entering the pump heats the pump body, evaporates the water at the interface of water being pumped (at the same time, some steam condenses). The steam also displaced water hence overcoming piping system resistance and lift water, giving it velocity at a certain height h_2 or discharge head (Fig 2). This was put in an equation form as follows:

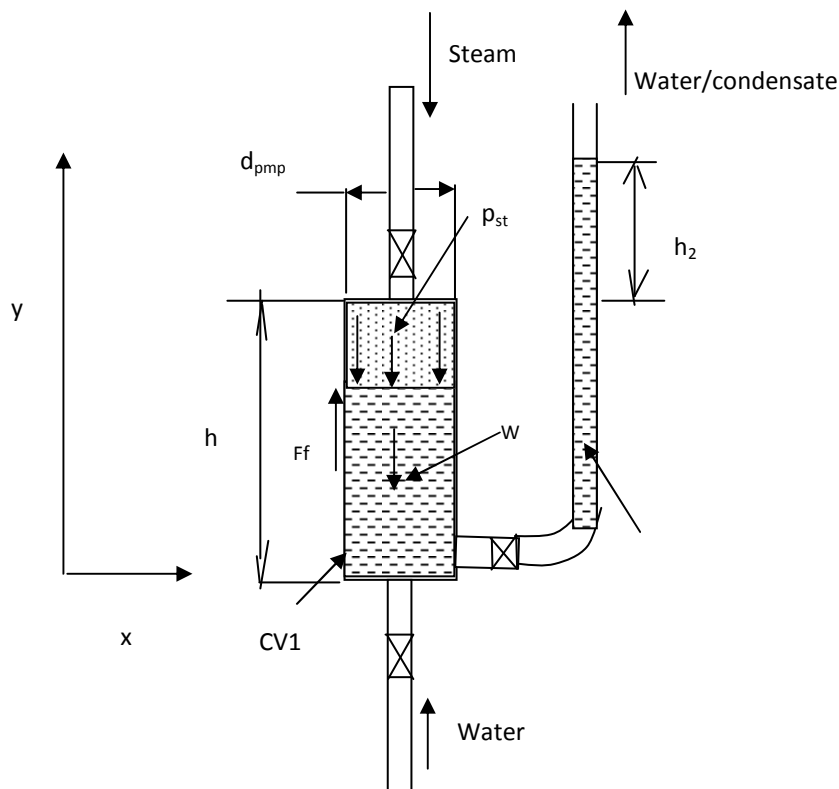

Fig 2: Forces diagram for the pumping stroke

Where: i_{st} - enthalpy of steam entering the pump; Q_{wall} - heat transferred through the walls of the pump; dh/dt - displacement rate of water at the steam water interface; h_2 - height displaced by water in the pipe system (discharge head); k - loss coefficient taking account of the losses in the piping system and the pump; A - area of the pump, ρ_{st} density of the steam. The following assumptions were made, during water displacement by steam:

- (i) Water is incompressible;
- (ii) The pump and the two fluids have uniform properties along the horizontal plane;
- (iii) Reversal of the pumping stroke is caused by condensation of steam;
- (iv) At the time of condensation pressure of steam is zero and as condensation takes place the pressure becomes negative;
- (v) As the steam displaces water it condenses and as the water is displaced and warmed up it evaporates, however the net heat transfer at the interface of water and steam is not zero, steam gives more energy for heating water.

Heat transfer from steam to the pump walls is the main driving force in the operation of the pump, apart from steam (pressure) itself, as it causes the suction and refill of the pump, through condensation. The heat transferred through the pump cylinder walls to surrounding by steam during the displacement and before suction of water into

the pump, is calculated by using equation (3) [ASHRAE Handbook of Fundamentals, 1989],

$$\frac{\alpha D}{k} = 1.86 \left[\left(\frac{\rho V D}{\mu} \right) \left(C_p \frac{\mu}{k} \right) \left(\frac{D}{L} \right) \right]^{\frac{1}{3}} \left(\frac{\mu}{\mu_s} \right)^{0.14} \quad (3)$$

since the condition of the steam flow has been found experimentally to be laminar. For laminar flow inside vertical tubes [ASHRAE Handbook of Fundamentals, 1989] the equation below was used:

$$\frac{\alpha D}{k} = \left[\left(\frac{\rho V D}{\mu} \right) \left(C_p \frac{\mu}{k} \right) \left(\frac{D}{L} \right) \right] < 20 \quad (4)$$

as the condition that the right hand side of equation (4) is less than 20 was observed.

Where: α is heat transfer coefficient W/m^2K , k thermal conductivity $[W/mK]$,

ρ is density of water $[m^3/kg]$, V velocity $[m/s]$, D diameter of the pump $[m]$,

L length of the pump $[m]$, μ absolute viscosity $[Pas]$.

A mean logarithmic temperature difference $(\Delta T)_{LMTD}$ from the following equation was used:

$$Q = UA(\Delta T)_{LMTD} \quad (5)$$

Where: U is the overall heat transfer coefficient of the pump. It was used to calculate heat transfer from

$$\frac{1}{U_1} = \frac{d_{pmp}^2}{\alpha_0 (d_{pmp} + \frac{1}{2}t)^2} + \frac{td_{pmp}^2}{k (d_{pmp} + \frac{1}{2}t)^2} + \frac{1}{\alpha_1} \quad (6)$$

where: t thickness of the pump, k thermal conductivity of the pump material, subscript i

stands for internal or steam side of the pump, while subscript o stands for outside of the pump. The flow of the steam and water displacement in the pump

$$-p_{st}A - W + F_f = \frac{\partial}{\partial \tau} (V\rho_w Ah) - V(\rho_{st}VA) + (V\rho_wVA) \quad (7)$$

$$W = \rho_w hAg \quad (8)$$

where: W is the weight of the fluid (kg); F_f - Friction force due to fluid shear at the boundary surface caused by fluid flow (N), A - cross section area of the pump (m^2), τ - time (s), h - distance covered by the moving fluid (pump height - m), V - velocity at the interface of water and steam (m/s), p_{st} - pressure of steam (N/m^2), ρ_{st} , ρ_w - density of steam and water respectively (kg/m^3),

Velocity and acceleration can be considered in terms of displacement h as follows:

the pump, having found the different individual heat transfer coefficients given in the following equation.

was studied also through momentum and mass conservation as shown in Figures 2 and 3.

Considering the control volume CV of figure 2 and 3:

$$V = -\frac{dh}{d\tau}; \dot{V} = -\frac{d^2h}{d\tau^2} \quad (9)$$

The solution of these equations 6, 7, 8 gives the displacement, velocity and acceleration of the fluid in the pump as displacement takes place.

Suction (refilling) stroke model

Likewise the equation for suction stroke can be formed similar to the case of pump displacement:

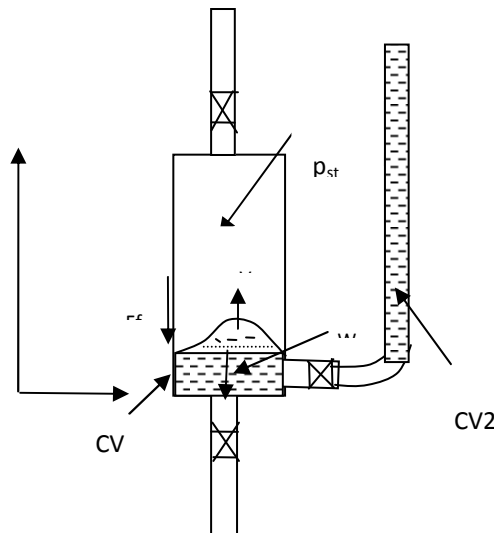

Fig 3: Forces diagram for the suction stroke

$$-W + A(-p_{st} + p_a) - F_f = \frac{\partial}{\partial \tau} (V_3\rho_w Ah) - V_3(\rho_w V_3 A) \quad (10)$$

The equations (6, 7, 8 and 9) represent displacement and suction strokes of the pump. Solution of the equations gave the displacement with respect to

time ie velocity as well as acceleration for a given pressure. Thus the equations have described the pumping process.

Conditions for displacement of water in the pump

The forces originating from steam pressure, in order to cause displacement, have to be able to overcome weight of water being pumped, overcome system resistance and the discharge head and give acceleration to the fluid being pumped see Figure 2 and equation 6.

Conditions for reversal of the pumping process in the pump

The forces described above give acceleration and raise water, thus increasing potential and kinetic energy of the fluid. These forces are counterbalanced by the forces due to the acquired head and system resistance, thus acceleration being reduced until it becomes zero. At this unstable equilibrium, heat transferred from the steam to surrounding, takes advantage of this equilibrium situation to be dissipated, and condensation is caused after saturated or super saturated conditions are formed. Thus, the forces that cause the displacement suddenly become lesser than the forces, which were being overcome. The process is reversed. Because of the non-return valve, fresh water is sucked in from the reservoir as a result of low pressure, which follows condensation.

The amount of heat transferred through the pump wall and the amount of steam entering the pump can be known at any position, given time, which can be used in solving equation (2) and (9). The results of solving these equations have given complete description of the pumping processes for any given instant.

The simplified equation for fluid flow in the pipe is given below, equation (10) which was considered with experimental rig of Figure 4, taking into account all the rig (system) bends, gauges, connections and frictional losses,:

$$P_{\text{steam(total)}} - P_{\text{water(total)}} - \Delta p_{\text{(losses)}} = 0 \quad (11)$$

Where the losses above are given as follows: given the details of the system as represented by Figure 4

$$\Delta p_{\text{(losses)}} = \Delta p_{\text{(pump)}} + \Delta p_{\text{(ex pump)}} + \Delta p_{\text{(va)}} + \Delta p_{\text{(gag)}} + \Delta p_{\text{(bend)}} + \Delta p_{\text{(sys)}} + \Delta p_{\text{(ex pipe)}} \quad (12)$$

Where:

$\Delta p_{\text{(pump)}}$ - frictional losses in the pump cylinder as the water is displaced by steam

$\Delta p_{\text{(ex pump)}}$ - pressure losses at the exit of the pump body

$\Delta p_{\text{(va)}}$ - pressure losses in the valve

$\Delta p_{\text{(gag)}}$ - pressure losses at gauge

$\Delta p_{\text{(bend)}}$ - pressure losses at the pipe bends

$\Delta p_{\text{(sys)}}$ - pressure losses in the piping system

$\Delta p_{\text{(ex pipe)}}$ - pressure losses at the exit of the outlet pipe.

Equations (11 and 12) simplifies to the following two equations by substituting the fluid flow equation in pipe and taking account friction as it appears in the actual rig represented in Figure 4 and summing up to get for all bends gauges etc total loss k_{tot} :

$$p_{st} = \frac{\rho V_w^2 k_{tot}}{2} + \rho g h_{\text{(disch)}} \quad (13)$$

$$V_w = \left(\frac{dp}{d_{pmp}}\right)^2 [2(p_{st} - \rho g h) / \rho k_{tot}] \quad (14)$$

Where d_p is the pipe diameter and d_{pmp} is the diameter of the pump.

Efficiencies of the Pump

Efficiency of the pump was found using the non conventional formula for pumps as given by following equation 15,

$$\eta_{pmp} = \frac{W_d - W_{loss} + W_{suc}}{Q_{suc}} \quad (15)$$

W_d - Work done per cycle

W_{loss} - Work Losses

W_{suc} - Suction work

Q_{suc} - Energy supplied per cycle

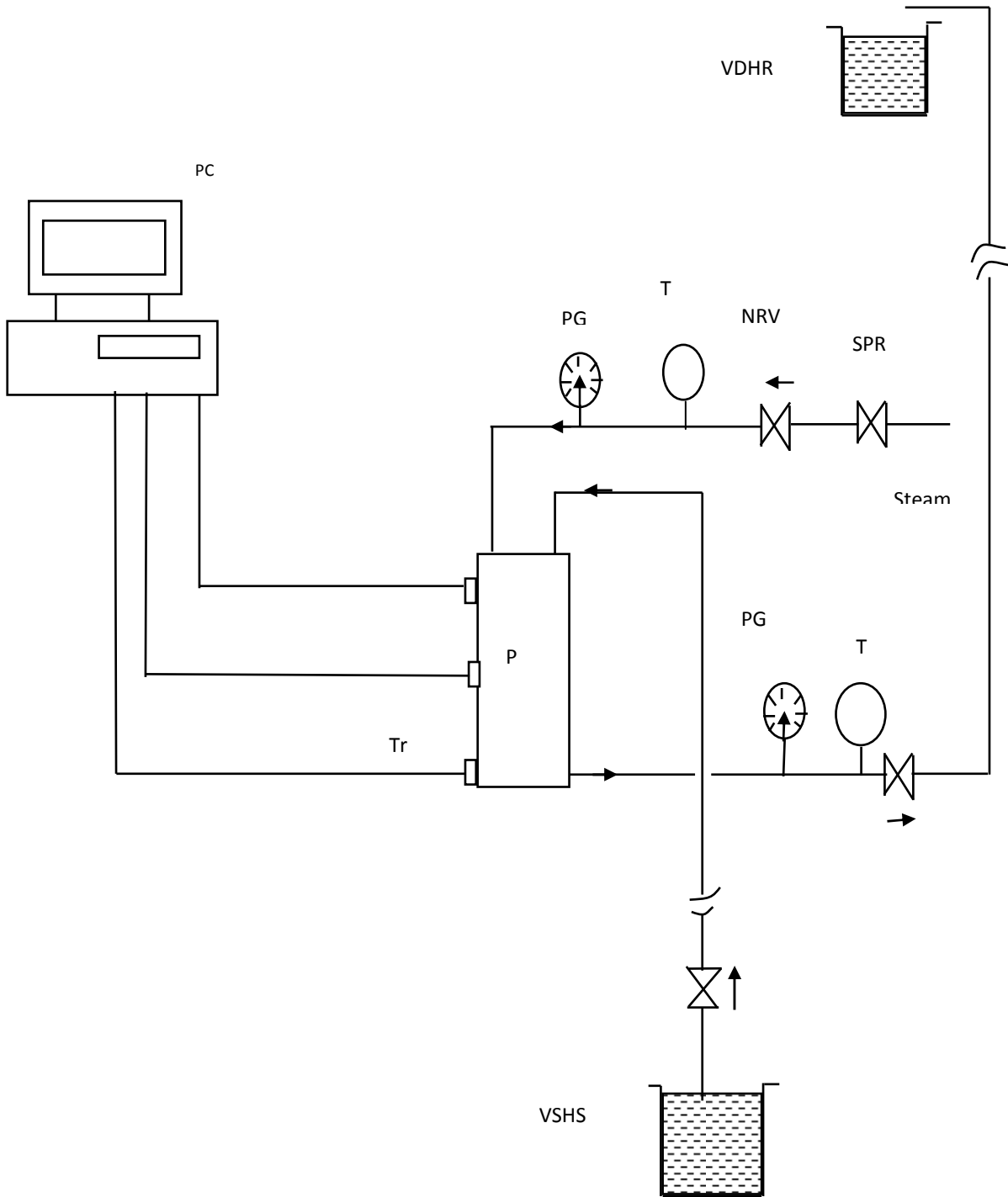

Fig 4: Experimental Test Rig for the MPTP

RESULTS

Inlet water temperature 28 °C, diameter of pump $D_{pmp} = 76$ mm, pipe inlet diameter $d_p = 12$ mm, suction head 0 m.

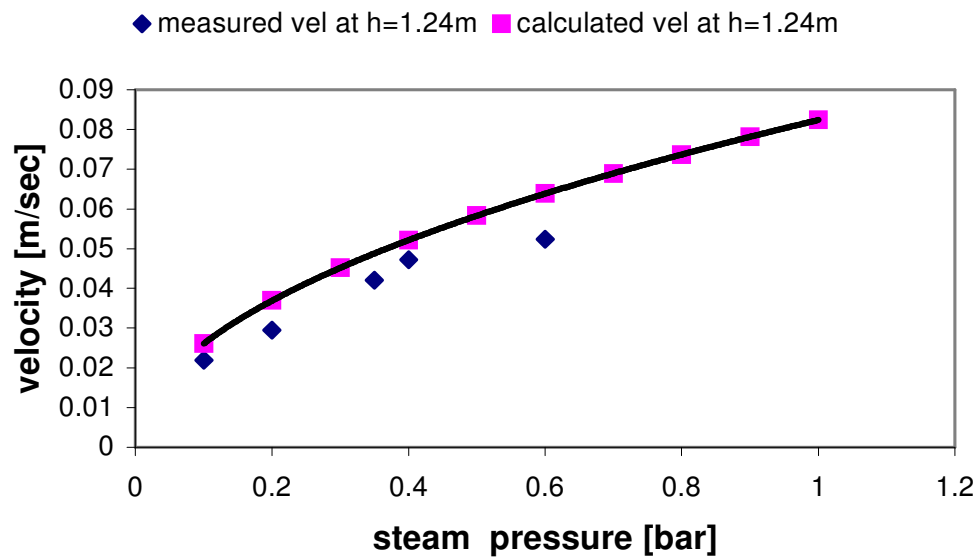

Fig. 5: Steam Pressure Versus Velocity for Discharge Head of 1.24 m

Inlet water temperature 28 °C, diameter of pump $D_{pmp} = 76$ mm, pipe inlet diameter $d_p = 12$ mm, suction head 0 m.

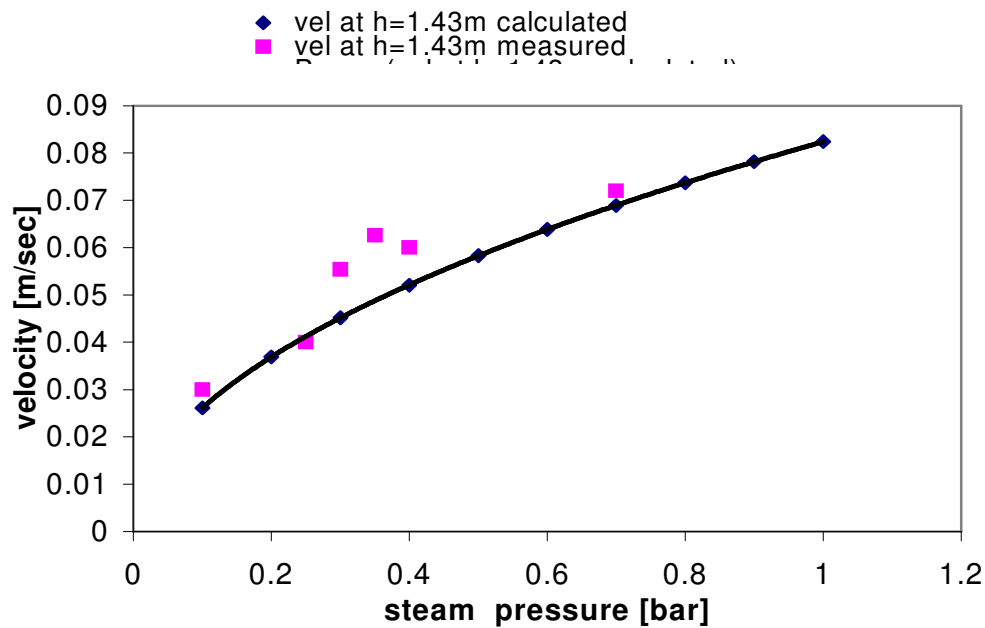

Fig.6: Steam Pressure Versus Velocity for Discharge Head of 1.43 m

Inlet water temperature 28 °C, diameter of pump $D_{pmp} = 76$ mm, pipe inlet diameter $d_p = 12$ mm, suction head 0 m

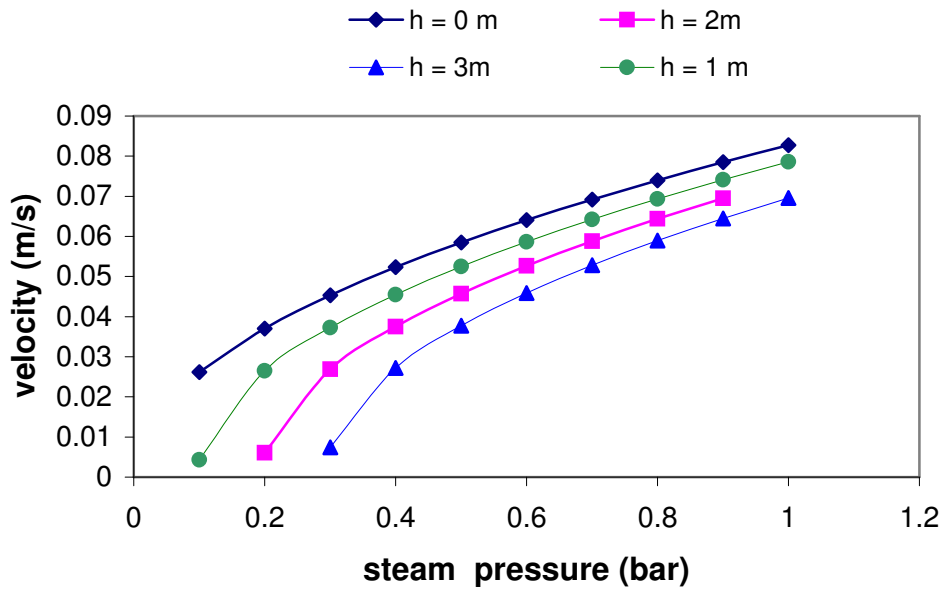

Fig 7: Steam Pressure vs Velocity Prediction for Different Water Discharge Heads ($p = 0.1 - 1$ bar).

The Reynolds number indicated that most of the experiments on the operations of the pump were in transition or laminar flow regime. This was further substantiated by the experiments done on the glass pump, which was visible. In the turbulent range the

pump failed to operate. This failure was attributed to the high speed of the pumping process, which in turn helps to stress the earlier proposed heat transfer influence of the operation of the pump.

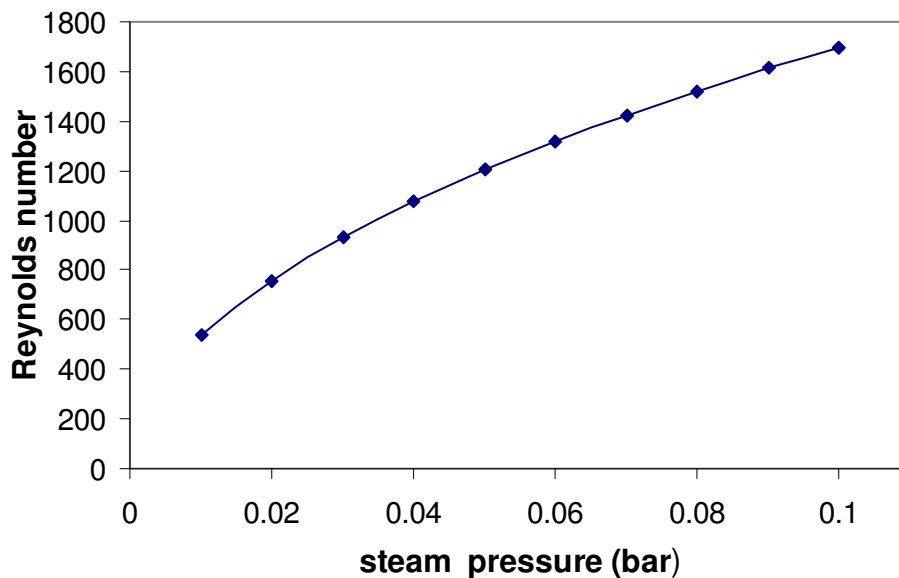

Fig 8: Steam Pressure vs Reynold's Number Prediction for Water Displacement

Heat transfer coefficients, overall heat transfer coefficient and heat transferred from steam through the pump body have been shown to have influence on the pumping characteristics of the pump mainly on the volume flow rate and the diameter of the pump [Chami, 2004]. For example, for a fixed thickness of the pump, heat transfer coefficient of

the pump wall material increased for a fixed diameter as velocity increased, but as the diameter increased it decreased. It was shown that the volume flow rate of the small pump diameter will be almost the same as that of big diameter pump, for a fixed amount of heat, despite the amount of steam flow.

CONCLUSIONS

1. Dimensionless parameters were found Re , Eu , Fo and h/d_{pmp} theoretically.
2. It was experimentally shown that the Reynolds number found gave limit of flow operating regime of the pump. It was in the laminar and transition regime. The Euler dimensionless number gave the dependency of interface velocity on pressure relation. The Fourier dimensionless number gave the influence of heat transfer properties of the material of the pump to the operating characteristics.
3. Average interface velocities in the pump were found by assuming steam incompressible and using pipe flow energy and mass conservation equations.
4. Through heat transfer calculations for steam flow in a pipe, it has been explained and shown how the change of heat transfer coefficient, overall heat transfer coefficient and heat transfer through the pipe walls are directly connected to the experimental findings of volume flow rates.
5. Conditions for operation of the pump, which is pumping and suction, have been established based on energy, momentum and mass conservation.
6. Instantaneous displacement with respect to time of fluid in the pump has been established [Chami, 2004]. The theoretical cycle time agrees well with the experimental findings, while mass of steam used for pumping for each cycle differed slightly from 1% to 7%.

It was thus concluded that the simplified mathematical formulations for multi phase thermal pump can be used for design purposes and also for prediction of working conditions including capability and limitations of the pump.

ACKNOWLEDGEMENT

The experimental part of this work was done in the Energy and Chemical Engineering Departments and sponsored by the Research Committee of the University of Dar es Salaam (through the then Post Graduate Directorate). The cooperation and help of Colleagues in the College of Engineering and

Technology, University of Dar es Salaam, is appreciated.

REFERENCES

- ASHRAE Handbook** of Fundamentals (SI Edition), 1989 American Society of Heating Refrigeration and Air Conditioning Engineers, Inc., 1791 Tullie Circle, N.E., Atlanta, GA30329.
- Chami, F. A.**, (2004) "Investigation of Performance Characteristics of Multi Phase Thermal Pump", PhD Thesis, University of Dar es Salaam, pp104.
- Chami, F.A.**, (2007) "Experimental Investigation of Steam Multi Phase Thermal Pump at Low Pressure"; Paper sent for publication.
- Mushi, E.M.J., and Chami, F.A.**, (2000) "*Experimental Investigation of Steam Multi Phase Thermal Pump*," African Journal of Science and Technology, Vol 1 No. 2 pp 73-77,.
- Picken, D. J.**, (1987) "*Some applications of water piston engines*," Proceedings of the 2nd International Conference on Small Engines and Their Fuels in Developing Countries," University of Reading 23-24 September.
- Picken, D. J.**, (1990). "*Design and manufacture of thermally operated pumps*", Third International Conference on Small Engines and Their Fuels for Use in Rural Areas – Development, Operation and Maintenance, University of Reading, U.K. 17 – 19 July
- Picken, D. J., Seare, K.D.R., and Goto, F.**, (1997). "*Design and Development of a Water Piston Solar Powered Steam Pump*", Solar Energy, Volume 61, Number 3, pp 219 – 224,
- Rao D. P., and Rao K. S.**, (1976). "*Solar water pump for lift irrigation*" Solar Energy vol. 18, pp23-24,
- Walker, H. A., and Davidson, J. H.**, (1990). "*Analysis and simulation of a two phase self pumping solar water heater*", 20th Annual International Solar Engineering Proceedings and Conference, ASME,